

# BRISTAN

## Installation Instructions

Macadamia Sink Mixer  
with Pull Out Handset

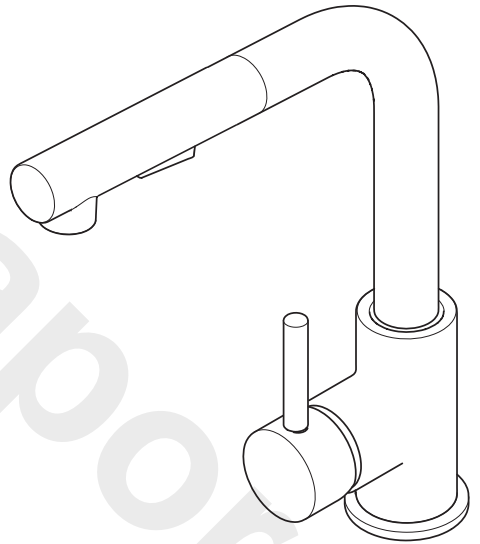

**Model covered:** MCD PULLSNK C

Please keep this booklet for future reference.

Installer, when you have read these instructions please ensure you leave them with the user.



# Contents

Thank you for choosing Bristan, the UK's leading taps and showers expert.

We have designed this product with your enjoyment in mind. To ensure that it works to its full potential, it needs to be fitted correctly. These fitting instructions have been created to give you all of the information you need and, if you need any further help, please do not hesitate to contact us.

Important Safety Information.....	3
Warning from your water Supplier .....	4
General Information.....	5
Specifications .....	5
Dimensions.....	6
Installation Requirements .....	7-8
Installation.....	9-10
Operation .....	11
Maintenance .....	12
Troubleshooting.....	13
Guarantee .....	14-15

# Important Safety Information

- Please read these instructions thoroughly and retain for future use.
- All products manufactured and supplied by Bristan are safe provided they are installed, used correctly and receive regular maintenance in accordance with these instructions.
- **If you are in any doubt about your ability to install this product safely you must employ the services of an experienced qualified plumber.**
- This fitting needs to be installed in accordance with, and meet the requirements of the Water Supply (Water Fittings) Regulations 1999 and Scottish Byelaws 2004.
- Remove all packaging and check the fitting for damage before starting installation.
-  **Warning:** Before starting any installation please consider the following: before drilling into walls, check that there are no hidden electrical wires, cables or water supply pipes. This can be checked with the aid of an electronic detector.
- If power tools are used do not forget to:
  - Wear eye protection
  - Unplug equipment after use
- **Important:** Remember to turn off the mains water supply before connecting to any existing pipe work. Fitting isolating valves to the inlet feeds is recommended for ease of maintenance.
-  **Warning:** Before installing the new fitting it is essential that you thoroughly flush through the pipework in order to remove any remaining swarf, solder, etc. Failure to carry out this procedure could cause problems or damage to the workings of the fitting.
- Take care when handling the 'flexible connecting pipes', do not bend, twist or crush them. Only tighten the pipes by hand.
- This product **must not** be modified in any way as this will invalidate the guarantee.

# Warning from your water Supplier

- It could be a criminal offence to use this tap with a mains water supply drawn directly from the supply pipe (the supply pipe is the one which brings the water supply into your home and is directly connected to the public water main).
- This tap has an outlet on a flexible hose which, if immersed in water, could result in contaminated water being drawn back into the pipework if the supply pressure dropped. To prevent contaminated water being drawn back into the pipework if the supply pressure dropped. To prevent contamination of drinking water in the premises and in the water main, and to comply with the legal requirement of the UK plumbing regulations and byelaws\*, **both hot and cold water supplied to this tap must come from a storage cistern.**
- If the distributing pipes feeding this tap from the storage cistern have other outlets connected to them, the outlet of this tap must be lower than any of those other outlets.
- If installed as a tap which is used for drawing water for drinking, and the quality of water from the storage cistern does not meet the standards for drinking water, a separate tap supplied with wholesome water must be provided for drinking purposes.
- For further information, contact the Water Regulations department of your local Water Supplier (see WRAS website [www.wras.co.uk](http://www.wras.co.uk) or Yellow Pages for details) or the Water Regulations Advisory Scheme by e-mail ([info@wras.co.uk](mailto:info@wras.co.uk)) or telephone: 01495 248454.
- The Water Supply (Water Fittings) Regulation 1999 in England and Wales; The Scottish Water Byelaws 2004 and Northern Ireland Regulations.

## General Information

This product has been tested to the Water Regulations Advisory Scheme (WRAS) and satisfies the requirements of the Water Supply (Water Fittings) Regulations 1999 and current bylaws. For full Installation Requirements & Notes (IRN) please visit [www.wras.co.uk/directory](http://www.wras.co.uk/directory).

Designed to comply with BS EN 200 for combination taps to be used within systems designed to BS 8558.

BS 8558 recommends hot water should be stored and distributed at a temperature of not less than 60°C which will minimise the build up of limescale in hard water areas.

If the fitting is installed at low pressure (tank fed), then the minimum distance from the highest installed position of the outlet to the underside of the cold tank should be at least 15 metres to ensure adequate performance.

This tap should be installed in compliance with the Water Regulations. Where the supplies are unbalanced, i.e. Hot water from cylinder tank / cold from the mains, approved check valves must be fitted in the supply pipes.

For further details contact your Local Water Authority.

## Specifications

Operating pressure range (bar)	Min 1.5	Max 5.0
--------------------------------	------------	------------

Maximum static pressure – 10.0 bar

Inlet Connections: M10 15mm Compression Flexible Tails with Isolation valves

System Requirements:

Gravity fed hot & cold (Equal pressures)

Gravity fed hot & cold (Differential pressure, maximum ratio 5:1)

Unvented systems

Instantaneous water heater (Combination boiler)

# Dimensions

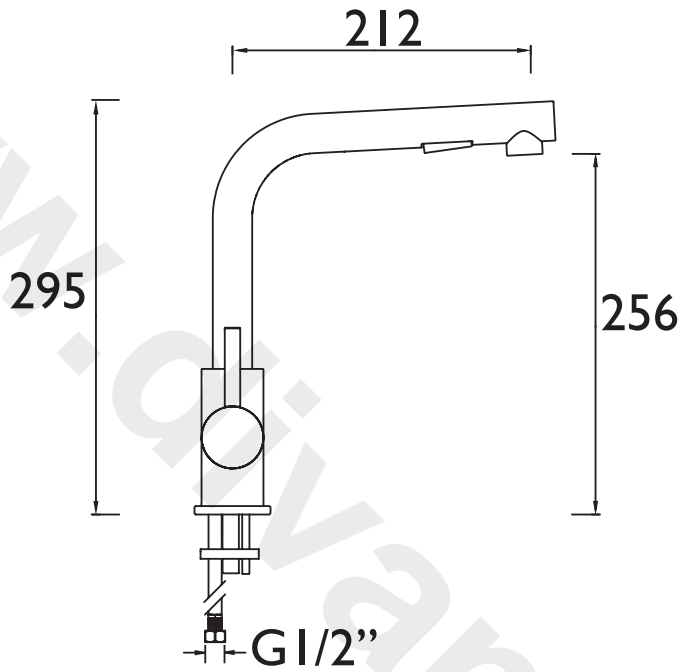

Dimensions are nominal and in millimetres.

# Installation Requirements

 **Warning:** This tap must be supplied from a storage cistern.

This fitting needs to be installed in accordance with the following Installation Requirements and Notes (IRN) to ensure they meet the requirements of the Water Supply (Water Fittings) Regulations 1999 and the Scottish Byelaws 2004. For further details contact your Local Water Authority.

## **For backflow protection in premises or installations up to fluid category 5.**

The vertical distance of the outlet above the spill-over level shall be not less than 20 mm or twice the diameter of the inlet pipe to the fitting, whichever is the greater. If the fitting cannot be installed as indicated it shall be installed:-

- a) With a backflow prevention arrangement suitable for the Fluid Category or
- b) so that it draws water by gravity only from a cistern, cylinder or tank having a permanently open vent pipe, the vertical distance between the point at which the pipe or pipes supply water to the fittings is or are connected to the supply and the spill-over level of any fixed appliances is not less than the dimensions stated above, and the vent pipe or pipes supplies no other fittings (other than a draining tap) at a lower level.

It is essential that all pipe work is flushed through to remove debris and swarf that could otherwise damage the fitting. Once the pipe work has been flushed through, turn off the water supply at the stop valve.

Two non-return valves are supplied with this mixer, one of each should be fitted in the hot and cold water supply to the mixer to prevent the possibility of backflow, however this mixer tap must be installed in accordance with the above mentioned Regulations.

 **Important:** Independent stop valves complying with the current water regulations should be fitted as a means of isolating both water supplies to the fitting for servicing and/or maintenance work.

Flush through the pipework to ensure removal of debris. Turn off the mains water supply, close any isolating valves and attach flexible connecting pipes.

**Important:** DO NOT OVERTIGHTEN. Carefully screw in the 'flexible connecting pipes'. (Tighten them by hand). Connect the flexible connecting pipes to the household water supply pipes.

# Installation Requirements Cont.

## Flexible Connecting Pipes

Care must be taken when connecting the flexible connection pipes to the household pipework to ensure they do not bend sharply and kink or twist.

See below for recommended ways to fit the flexible connecting pipes.

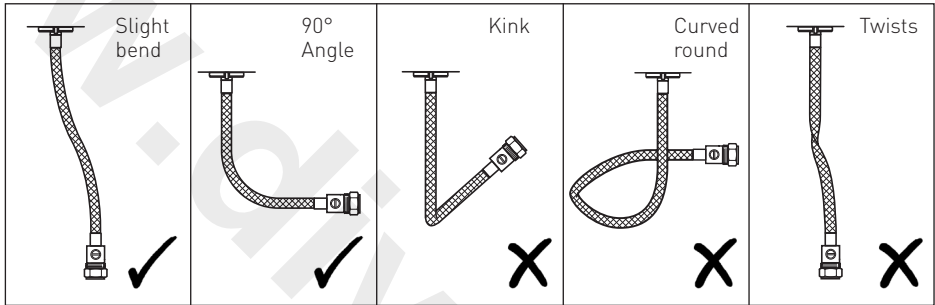

**⚠ Important:** Failure to follow these guidelines may result in poor performance and damage to the flexible connecting pipes.

**⚠ Important:** Full access must be made available on installation for future maintenance/ servicing purposes.

## Isolation Valves

The isolation valves must be accessible with a suitable flat-blade screwdriver for turning on and for future servicing purposes.

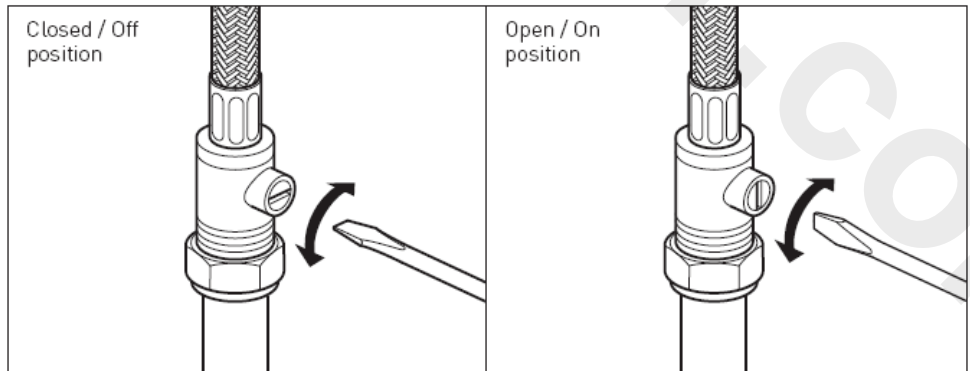

# Installation

1

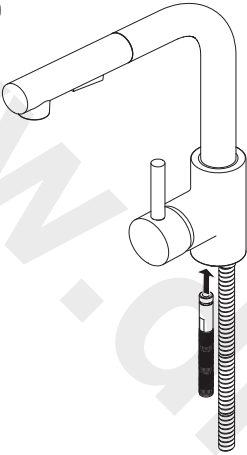

Screw the fixing rod into the bottom of the tap.

2

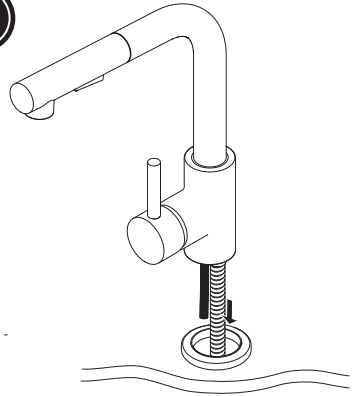

Place the plinth over the hole in the basin ensuring the washer is fitted between the plinth and the basin. Feed the hose through the hole.

3

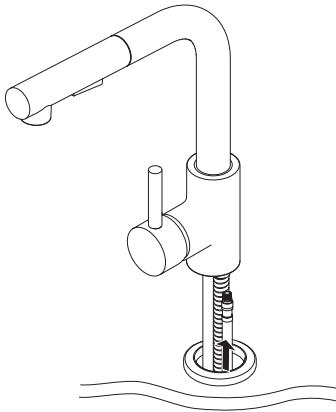

Feed the flexi tails from underneath of the basin and screw into the bottom of the mixer body by **hand only (DO NOT OVERTIGHTEN)**. Fit the mixer body onto the plinth.

4

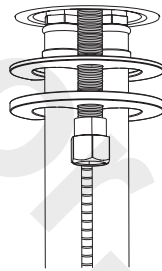

Slide 'C' shaped rubber washer and 'C' shaped metal washer onto the fixing rod up to the underside of the basin. To secure the mixer in place tighten the fixing nut onto the fixing rod until it is fully tightened against the 'C' shaped metal washer. A suitable spanner can be used to fully tighten the fixing nut.

## Installation Cont.

5

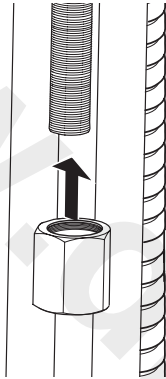

Screw the connection piece onto the fixing rod.

6

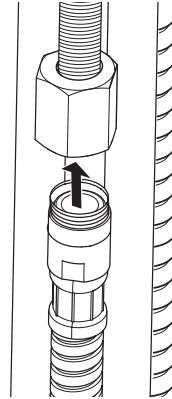

Attach the house to the connection piece.

7

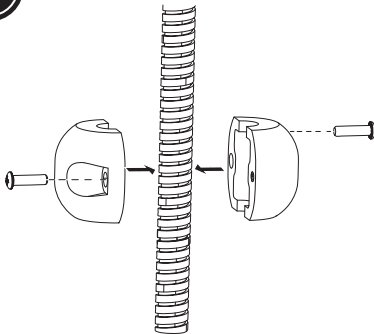

Place both weight halves around the hose (close to the bottom of the hose) and secure in place by using screws supplied

8

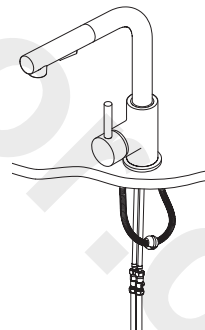

Connect the flexi tails to the hot and cold water supplies. Turn on the mains water supply and open the isolating valves using a suitable flat bladed screwdriver, letting the water flow for a few minutes to flush through the system. Check all joints and connections for any leaks.

# Operation

## Temperature Control

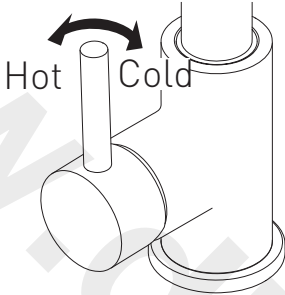

## Flow Control

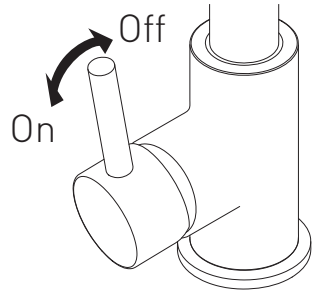

## Handset Operation

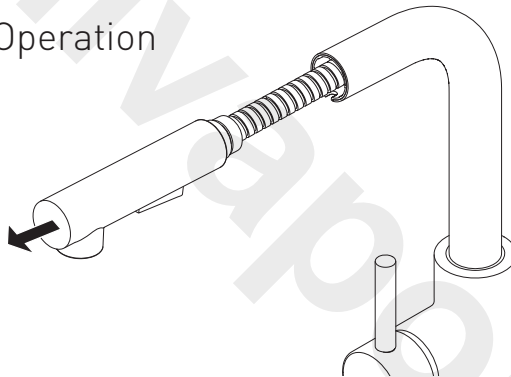

## Flow Pattern

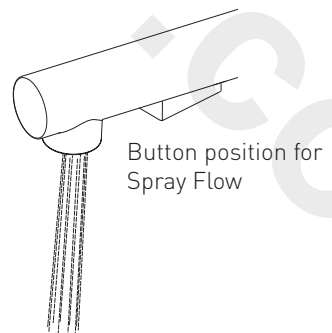
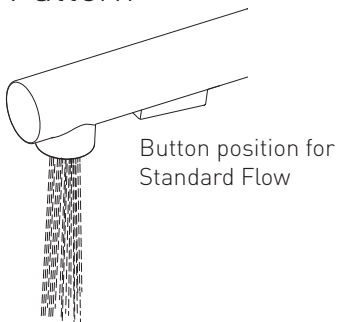

# Maintenance

## General Cleaning

Your fitting has a high quality finish and should be treated with care to preserve the visible surfaces. All surfaces will wear if not cleaned correctly, the only safe way to clean your mixer is to wipe with a soft damp cloth. Stains can be removed using washing up liquid. All bath cleaning powders and liquids will damage the surface of your fitting, even the non-scratch cleaners.

**Note:** Never use abrasive detergents or disinfectants or those containing alcohol, hydrochloric acid or phosphoric acid.

## Cleaning the Cartridge

Before carrying out any maintenance, turn off the mains water supply and close any isolating valves.

Unscrew the handle lever and loosen the grub screw using a 2.5mm hexagonal key. Remove the handle and shroud insert. Remove the cartridge retaining nut.

Remove the cartridge and clean thoroughly under cold water to remove any build up of limescale or debris.

If necessary replace the cartridge using parts supplied by Bristan only.

Replace the cartridge into the body, cartridge retaining nut, shroud cover and the handle. Tighten the grub screw and screw the handle lever back in.

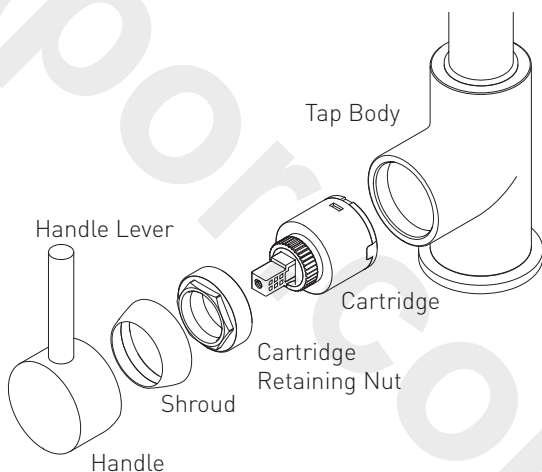

# Troubleshooting

Symptom	Cause	Remedy
No flow or low flow rate	Partially closed isolation valve.	Open isolation valve.
	Instantaneous water heater cycles on and off as flow rate or pressure is too low.	Increase water flow rate or pressure through system to meet required minimum working pressure of tap.
	Head of water is below the minimum distance required.	Refer to 'Specifications' on page 5.
	Hot or cold water being drawn off elsewhere causing pressure changes or instantaneous boiler temperature changes.	Do not use other water outlets when using the taps.
	Airlock or partial blockage in the supply pipework.	Flush through pipework to ensure removal of debris and any airlocks.
Water dripping from taps	This is normal for a short time after using the taps.	This is caused by capillary action, the build up of water in the tap body.
	If water continues to drip, possible build up of debris/ lime-scale in the cartridge	Remove and clean the cartridge, refer to 'Maintenance' section on page 12 before removing the cartridge.
Taps do not turn on	Closed isolation valve.	Open isolation valve.
	Mains water supply turned off.	Turn on mains water supply.

# Guarantee

At Bristan, we want to make things as easy as possible for our customers. That's why we design products that are easy to fit and use, and that are quality tested to make sure they won't let you down. It's also why we offer solid guarantees on all products, effective from the date of purchase, to give you peace of mind.

Bristan's Bathroom Taps are covered by a **5 year guarantee**. This also includes **5 year labour cover** \* (subject to registration) which means that, in the unlikely event that there is a problem in the first year after purchase, we'll send one of our expert engineers to fix it.

\*Labour is provided by an approved Bristan Care engineer or appointed representative. The guarantee only applies to products with a manufacturing fault. There will be a call out charge for any incidents where no fault has been found with the product, or if the issue is due to poor installation or maintenance.

## Guarantee Terms and Conditions

This guarantee is in addition to your statutory and other legal rights and is subject to the following conditions:

- The product was purchased within the United Kingdom or Republic of Ireland.
- The guarantee applies solely to the original purchaser with proof of purchase.
- The installation must allow ready access to all products for the purpose of inspection, maintenance or replacement.

- Repair under this guarantee does not extend the original expiry date. The guarantee on any replacement parts or product ends at the original expiry date.

- Any part found to be defective during the guarantee period will be replaced without charge, providing that the product has been installed in accordance with the instructions given in this guide and used as the manufacturer intended.

The guarantee does not cover:

- Damage or defects caused by;
  - General wear and tear (including special non-chrome finishes; components such as filters, seals, 'O' rings and washers)
  - Incorrect installation
  - Repair using non-Bristan parts
  - Accidental or wilful misuse
  - Corrosion and the use of inappropriate cleaning products
  - System debris including the build up of limescale (which can be controlled through regular servicing and maintenance)
- Compensation for loss of use of the product or consequential loss of any kind.

In the interests of continuous product improvement, Bristan reserves the right to alter product specifications without notice.

The Bristan Product Guarantee does not affect your statutory rights as a consumer.

# Guarantee & Service Policy

## • Need help?

If this product does not function correctly when first used, contact **Bristan Care Customer Service on 0844 701 6273** where our expert team of advisors will be able to offer you help and advice.

## • Problems during the guarantee period

In the unlikely event that you encounter any problems with the product during the guarantee period, contact **Bristan Care Customer Service on 0844 701 6273** with your proof of purchase and we will work to resolve the problem quickly.

## **Bristan Care Customer Support**

Bristan customers also benefit from the support of Bristan Care, our comprehensive customer support package which offers:

### **Technical support hotline**

(Tel: 0844 701 6273) with access to fully trained advisers who can offer installation advice, talk you through quick maintenance checks, or recommend the best course of action to fix any problems with a product.

### **Expert advice**

Find easy to follow 'how to' video guides and technical FAQs online at [www.bristan.com](http://www.bristan.com). Our guides take you step-by-step through many product installations and you can find plenty of easy guides to quick product fixes and servicing.

## **Spare parts**

We hold thousands of spares and we keep them for discontinued products for over seven years. Spares can easily be ordered online at [www.bristan.com](http://www.bristan.com) and are dispatched the same day.

## **Expert plumbing engineers**

If we can't solve the problem over the 'phone or with a spare part, then we'll send out one of our Bristan Care engineers to take a look. Bristan Care engineers provide free support for products that are within guarantee, but are also available to service products that are out of guarantee for a small charge. For details, please call **Bristan Care Customer Service on 0844 701 6273**.

Part Number: <b>MCD PULLSNK C</b>
Issue: D1

# BRISTAN

Bristan Group Ltd.  
Birch Coppice Business Park  
Dordon  
Tamworth  
Staffordshire  
B78 1SG  
Web: [www.bristan.com](http://www.bristan.com)  
Email: [enquire@bristan.com](mailto:enquire@bristan.com)

A Masco Company

## Useful contact details:

Customer Service:

**0844 7016273**

Customer Service Email:

**[Customercare@bristan.com](mailto:Customercare@bristan.com)**

Customer Service Fax:

**0844 7016275**

Reception:

**0844 7016274**

Join us on...

